

CAD FILE:

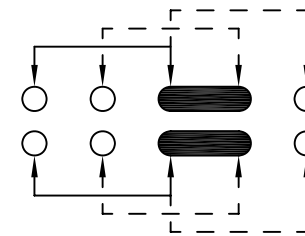

SCHEMATIC (SHORTING)

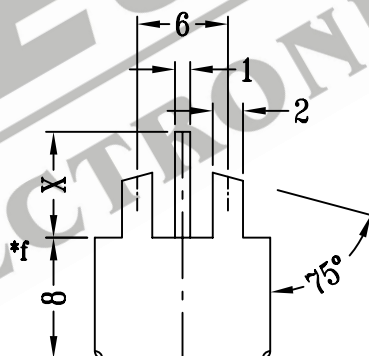
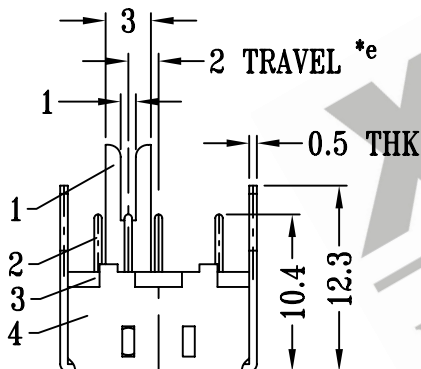
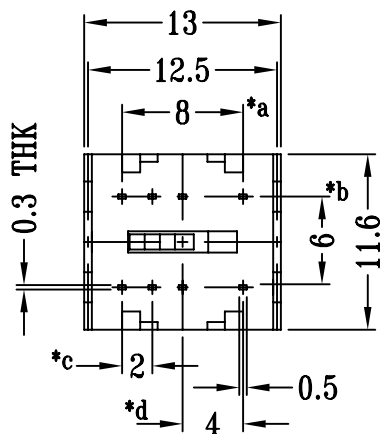
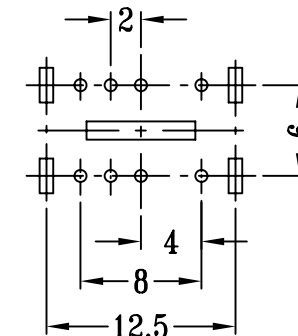

P.C.B LAYOUT

注:带"*"表示关键尺寸(6个)

8	PRESS BAR	POM	1	BLACK	TOLERANCE UNLESS SPECIFIED	SHENZHEN XIEJIA ELECTRONICS CO.,LTD.				
7	STEEL BALL	STEEL	2	NATURAL						
6	SPRING	STEEL WIRE	1	TEMPER	WITHIN: 1.5±0.1mm	ISSUE	DATE	DESCRIPTIONS		APPD.
5	CONTACT (CLIP)	PBS	2	Ag CLAD	OVER : 1.5±0.2mm					
4	FRAME	ZINE PLATE	1	WASHING	TITLE : BOTTOM SLIDE SWITCH		UNIT : MM	DRWG NO.: XJ-DR-BK23D03-00		
3	TERMINAL BASE	PHENOLIC RESIN	1	NATURAL	MODEL: BK-23D03		SCALE: 2:1	DWN.	ZHOUYU	2000-12-9
2	TERMINAL	BRASS STRIP	8	Ag PLATED OVER Ni PLATED				CHK'D	FANGYING	2000-12-9
1	STEEL KNOB	STEEL STRIP	1	Ni PLATED	ALL MATERIALS MUST BE COMPLIANT TO ROHS		APPD.	KANGXINAN	2000-12-9	
NO.	PART NAME	MATERIAL	Q'TY	FINISHING						